



The Apollo av-1 underwater scooter was originally developed to expand freedom of movement underwater. A vehicle allows the diver to move without having to kick much, thus using up to 50% less air. A greater distance can therefore be covered. Now you can travel further, get there faster, and have a lot more fun along the way.

• Specifications

construction: hydrodynamically designed • 3-part body made of shock resistant ABS resin • weight: 40 lbs with battery at surface ~ 1.5 lbs in water • dimensions: 14" x 24" • maximum speed: 2.4 mph • speed settings: 3 speeds controlled at the propeller assembly • maximum recommended depth: 165' • thrust: 40 pounds • motor: DC 12V magnetic field type • battery type: (GS) PE12V24A rechargeable • average burn time: 45 - 60 minutes • battery weight: 19 lbs • dual voltage charger for domestic and international travel • each unit includes one battery and charger • available in yellow • \$2000.00

• Safety features

A thermal sensor has been installed to protect motor, battery, and other electrical units from the dangerous effects of overheating • should water enter the battery housing or the motor housing, a leak sensor activates a warning lamp and shuts down the operation of motor • clutch is designed to disengage automatically if foreign matter becomes entangled in the propeller assembly • locking lever on power switch helps prevent accidental activation



• Options

The av-1 weighs 1.5 lbs in water. The optional oral inflation vest will keep it in sight when needed • \$120.00



Powered by Japan battery (GS)PE12V24A • rechargeable in 5 to 9 hours • spare battery includes plug • \$260.00 plug also available separately • \$30.00



• design

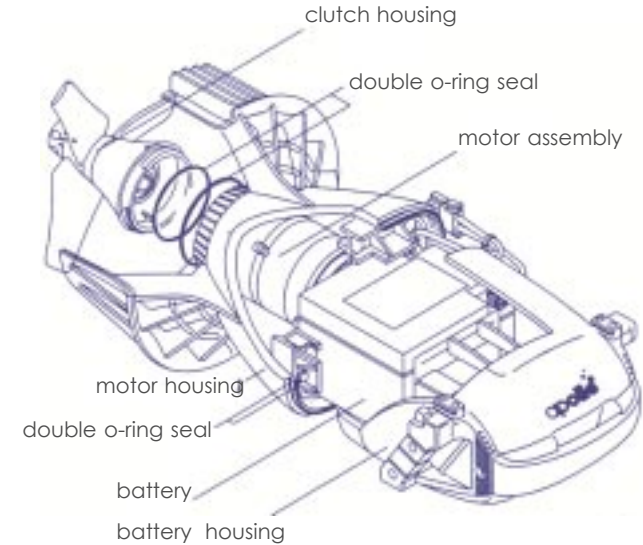

3 part body construction

To protect against potential water damage, the av-1 has been divided into three separate compartments. Each compartment can be easily checked for seal integrity and maintained as needed.

If water should happen to enter the body; the three part design will help minimize damage.

The clutch housing, where water can enter easily, is designed to simplify inspection and care after each dive.

• **Ready to travel**

The charger can be set for 115 or 230 volt. When packaged for travel; a complete vehicle is 17" x 17" x 29" and weighs 52 lbs.

Apollo av-1 is the choice of shops, resorts, and movie makers worldwide.



IMAX Films chose Al Giddings Images, Incorporated to film underwater footage for several 3-D movies. Mr. Giddings chose four Apollo av-1 vehicles to create his own propulsion system for the IMAX camera and housing unit.



Dolphins can spin, serve, turn, and swim effortlessly. So can we.

www.apollosportsusa.com

Visit us online for additional information on the av-1 underwater explorer. Also available from Apollo USA

- masks • snorkels • bio-filter • bio-fins • bio-seal • NEW al-110 regulator • ex drysuits for men and women



av-1 underwater scooter

Manufactured for over 15 years; the av-1 underwater scooter is one of the most reliable in the world.

apollo

12322 Hwy 99 South, Unit 102
Everett, Washington 98204
customer service (800) 231-0909
www.apollosportsusa.com

apollo